

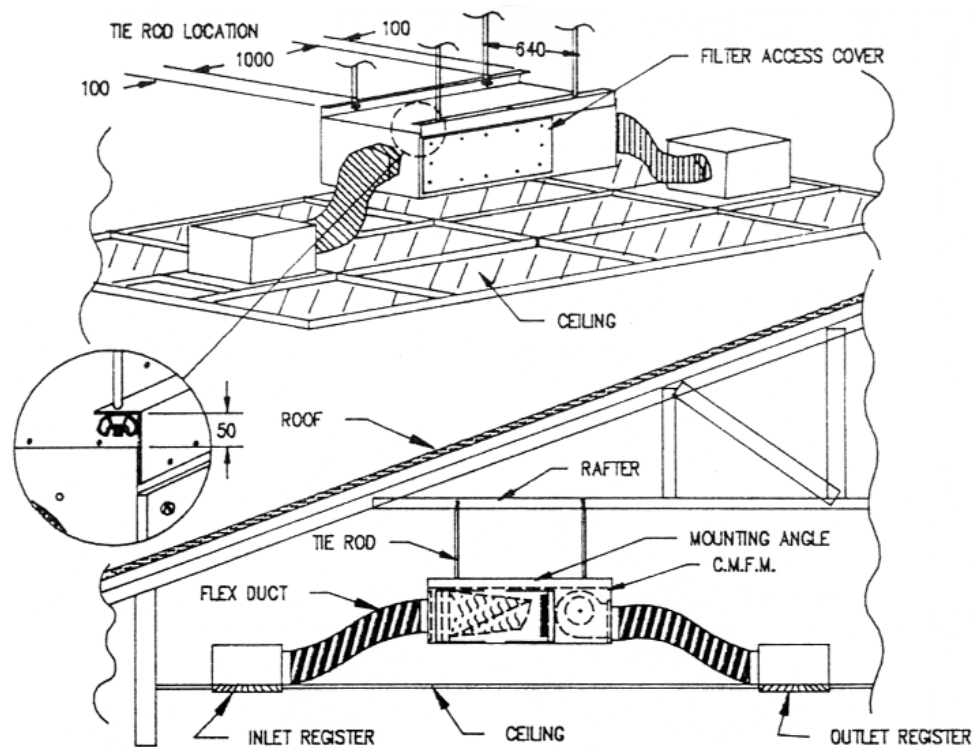

## Ceiling Mounted Filter Module



### Application

AES Environmental's Ceiling Mounted Filter Modules are designed for use in applications where high concentrations of airborne particles are encountered. The module is designed to fit above the ceiling, in the ceiling cavity. The registers and flexible ducting shown are not supplied with the module.

### Construction

The module is constructed from galvabond with two 300mm diameter spigots on each end. The fan is a 230mm - 240 volt centrifugal blower.

### Fan capacity

The fan can be fitted with a manually adjusted fan speed controller to vary the air flow as required.

### Installation

The module is supplied with hanging rails suitable for hanging rods to attach to roof rafters or concrete slab, placing no load on the ceiling structure. It must be mounted to give sufficient access for the servicing of the filters by the removal of the access cover.

Filter Type	Rating AS1324.1	Average Efficiency %	Maximum Air Flow	Maximum Air Flow with Carbon Filter	Module Part Number	Filter Replacement Part Number
MP 21/22 H	G4	90+ No.4	400 l/s	250 l/s	1516-CMFM/1	1516-4502/2
Compact P	F6	60-80 No.1	500 l/s	300 l/s	1516-CMFM/2	VPMP65610305300
	F7	80-90 No.1	500 l/s	300 l/s	1516-CMFM/3	VPMP85610305300
	F8	90-95 No.1	500 l/s	300 l/s	1516-CMFM/4	VPMP95610305300
	F9	95+ No.1	500 l/s	300 l/s	1516-CMFM/5	VPMP100610305300
HEPA c/w pre-filter.		99.97 Hot DOP	250 l/s	150 l/s	1516-CMFM/6	1589-7182/002 DPF50-305610
N.B. For carbon filter option add "C" after the Part Number.						1622-0330/1

## Power requirements

Each module requires a 240 volt - 10 amp supply with power supplied by either the air-conditioning system or general power supply.

## Limitations

The module is suited to small applications only, for use in non-critical areas. Multiple units may be installed in a common area.

## Maintenance/service

In all major population centres AES Environmental provides full filter maintenance, change over media, replacement parts and service facilities.

## How to specify

Filter module will be an AES Environmental Ceiling Mounted Filter Module with a ( Compact P F6 ) particulate filter and ( optional ) activated carbon adsorption filter. Module No. 1516-CMFM/2. Unit will include a 240 volt centrifugal blower c/w speed controller.

## Dimensions

Standard units will be 1100mm long x 600mm wide x 450mm high.

## Options

As these units have been designed around a standard module format they can be supplied with a number of combinations of filters to suit your requirements. E.G. In high dust load areas these units be fitted with a disposable cardboard pre-filter to prolong the life of the high efficiency final filter.



[www.aesenvironmental.com.au](http://www.aesenvironmental.com.au)

**Sydney:** Tel 1300 550 116 Fax 1300 550 117

**Address:** 19 Saggartfield road Minto NSW 2566 **Email:** Sales@aesenvironmental.com.au



**National Tel. Hotline 1300 550 116**

**National Fax 1300 550 117**

© 2011 AES Environmental  
AESE

Bulletin no. 8A.11.05AES104REV3