

Multi-Peak MP22 standard flow  
-overall depth 570

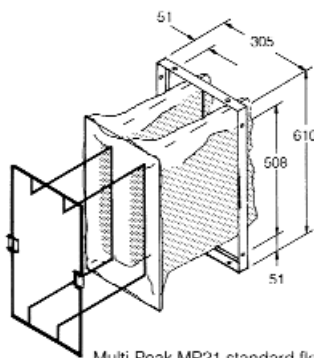

Multi-Peak MP21 standard flow  
overall depth 570

## Multi-peak™ Deep bed air filter

The Multi-Peak deep bed air filter is a compact and economical general purpose filter, ideal for applications where medium efficiency filtration is required, with its series of wedge shaped pockets providing excellent dust holding capacity.

**Low operation cost:** High dust holding capacity results in a long duty cycle.

**No separate mounting frame:** Multi-Peak filters can be made up into banks suitable for any given air capacity with the mounting frames being easily bolted or riveted together.

**Simple servicing:** The media is easily removed from the frame, ready for replacing with a new piece.

**Single plane sealing:** Maintenance personnel can visually check the seal between the media and frame.

### Construction details

Multi-peaks are formed to shape and sewn using multiple polyester threads with the full size MP22 being a 3 pocket configuration and the half size MP21 having 2 pockets.

The outer mounting frame is steel with the inner frame being of wire construction. Integral clips clamp both the inner frame and media to the mounting frame.

A powder coating on both the mounting and inner frames prevents corrosion, with the resulting smooth surface minimising the possibility of media snagging when being serviced. Stainless steel and Galvabond construction are also available.

### Maintenance/service

AES Environmental provides filter maintenance, replacement media, spare parts and servicing facilities Australia-wide.

When maintenance is required it is simply carried out with the inner wire basket of the assembled filter being removed by disengaging the clips and withdrawing it from the mounting frame.

When the new media is being installed, it is fitted over the inner frame with the assembly being inserted back into the mounting frame. Correct fitting ensures a seal is formed between the media and the mounting frame.

	DGH20	DG50
Filter performance rating	G4	F5
Test report reference	RALC00402AE	RALC00404
Initial Resistance	32 Pa	45 Pa
Initial Efficiency No.1 Dust	22%	32%
Average Efficiency No.1 Dust	34.00%	47.00%
Average Arrestance No.4 Dust	94.00%	95%
Dust Holding Capacity	1593g	1342g
Dust Holding Capacity per unit of Face Area	4576g /sqm	3989g /sqm
Test Air Flow Rate	944	944

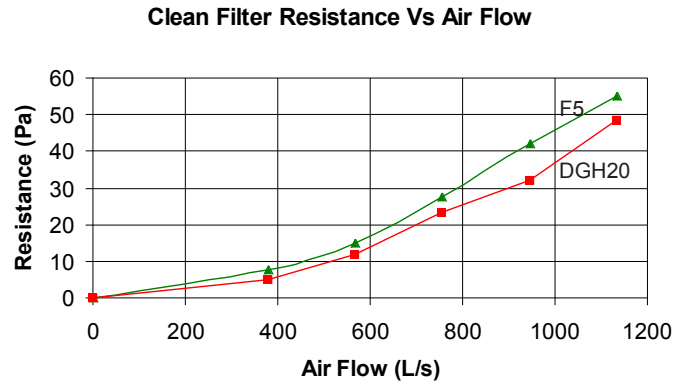

Description	MP22/HG	MP22/DGH20	MP22/DG50	MP22/KF2	MP22/KF
Performance rating	G4	G4	F5	F6	F6
Test report reference	RALC00397AE	RALC00402AE	RALC00404	RALC00368	RALC00367
Part No. - repl. Media	1516-4502/1	1516-4502/2	1516-4502/11	1516-4502/5	1516-4502/6
Media type to AS1324.1.2.1	Type 2 Class B	Type 1 Class A	Type 1 Class A	Type 1 Class A	Type 1 Class A
Dimensions* HxWxD (mm)	610x610x570	610x610x570	610x610x570	610x610x570	610x610x570
Weight* (kg)	7.5	7.1	7.2	7.6	7.6
Media area (m <sup>2</sup> )	1.7	1.7	1.7	1.7	1.7
Rated capacity (m <sup>3</sup> /s)	0.944	0.944	0.944	0.944	0.944
Initial resistance @ rated capacity (Pa)	30	32	45	120	90
Recommended final resistance @ rated capacity (Pa)	125	125	125	250	250
Dust holding capacity (g) @ rated capacity	815	1593	1342	2193	2037
Max. operating temperature (°C)	120	120	100	120	120

Notes: 1. Filter specifications subject to change without notice.  
2. No. 2 & 3 test data available by request

\* based on standard flow MP22 including inner and outer frame

## Performance testing

All filters tested to AS1324.2.4-5: Air Filter Performance.

Test laboratory is accredited by the National Association of Testing Authorities, Australia. Accreditation number 13213.

Performance tests are conducted at least once every 5 years within a controlled environment in accordance with NATA and Australian Standards requirements.

To request a current test report contact the sales team at your nearest AES Environmental branch.

## How to specify

Air filters shall be Email Air Handling Multi-peak or approved equal, 610 x 610 face dimensions, 0.944m<sup>3</sup>/s capacity, fitted with (specify media type) media.

At rated capacity, average efficiency test procedure shall be not less than (see chart)% with a dust-holding capacity increase of at least (see chart) g.

Current AS1324-compliant test report should be available and supplied on request. Mounting frame and inner frame shall be coated (or specify Galvabond / Stainless steel) to resist corrosion.

## Installation

Multi-peak filters are easily made up into banks using standard 610 x 610 (MP22) and 305 x 610 (MP21) module sizes. To prevent air by-pass, a suitable sealant should be used between mounting frames and duct walls. Where the bank height exceeds 2 metres it is recommended that continuous stiffening bars be installed vertically between alternate rows of frames.

## Addresses

**Sydney:** Tel 1300 550 116 Fax 1300 550 117

**Address:** 19 Saggartfield Road Mint NSW 2566 **Email:** Sales@aesenvironmental.com.au



[www.aesenvironmental.com.au](http://www.aesenvironmental.com.au)



**National Tel. Hotline 1300 550 116**

**National Fax 1300 550 117**

© 2011 AES Environmental  
AESE