



Absolute Type Filter Mounting Frames

The Email mounting frame system has been designed for use in single or multiple absolute type filter installations.

Each 14 gauge zinc-dichromate plated mild steel frame is precision pierced to permit rapid on-site installation with 3/16" diameter solid rivets. Before riveting, all sides of the mounting in contact with other frames or duct housings should be coated with a suitable mastic sealant.

When installed, the side of the mounting frame with double alignment strips should be in the downward position so that the filter will bear evenly against the inside flange.

Each mounting frame is supplied with four removable clamp assemblies which are attached to each inner corner of the mounting frame. Each clamp assembly comprises a clamp arm, screw and spring. This assembly provides a constant pressure against the filter gasket after the filter is installed and the clamp screw adjusted.

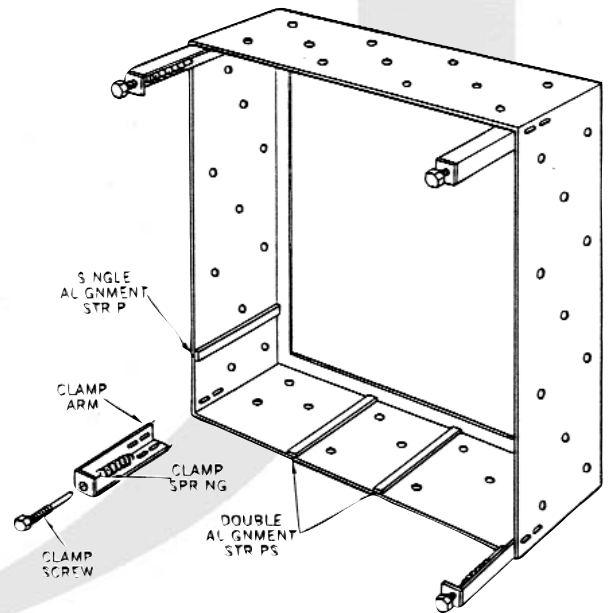

This constant pressure compensates for any set or deformation the gasket may experience after initial installation and ensures a constant seal at all times.

To suit filter size (mm)	Mounting frames actual size (mm)	Overall depth including clamps (mm)	Part No.
305 x 305 x 149	327 x 327 x 152	267	1589-0010/303
610 x 610 x 149	632 x 632 x 152	267	1589-0010/304
610 x 610 x 292	632 x 632 x 203	406	1589-0010/305
610 x 762 x 292	632 x 784 x 203	406	1589-0010/306
610 x 762 x 149	632 x 784 x 152	267	1589-0010/307
610 x 1219 x 149	632 x 1241 x 152	267	1589-0010/309

AES Environmental

www.aesenvironmental.com.au

Sydney: Tel 1300 550 116 Fax 1300 550 117
Address: 19 Saggartfield Road Minto NSW 2566
Email: sales@aesenvironmental.com.au



National Tel. Hotline 1300 550 116

National Fax 1300 550 117

© 2011 AES Environmental (SA) Pty Ltd
ABN 74 136 515 430

Bulletin no. 8A.11.05AES103 REV2